

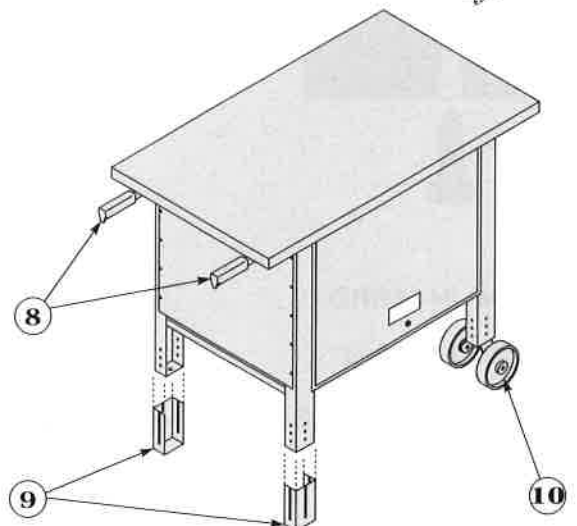

banco WERKMEISTER

ISTRUZIONI DI MONTAGGIO

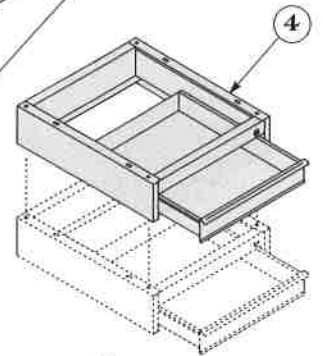
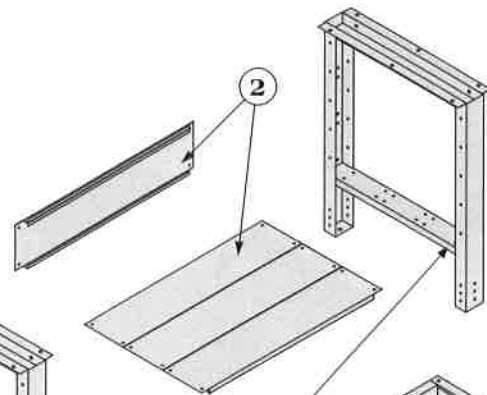
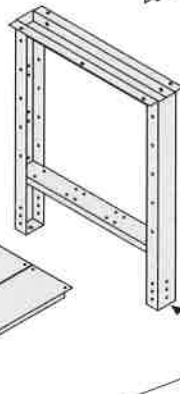
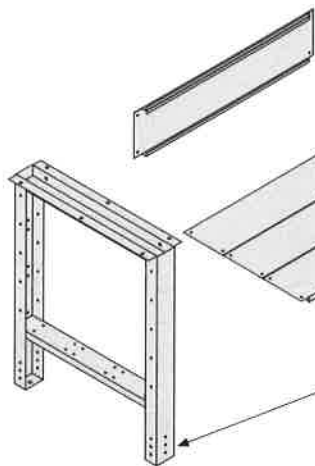
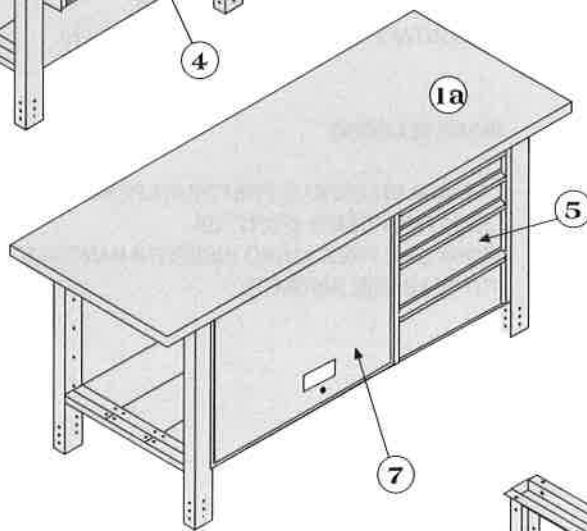
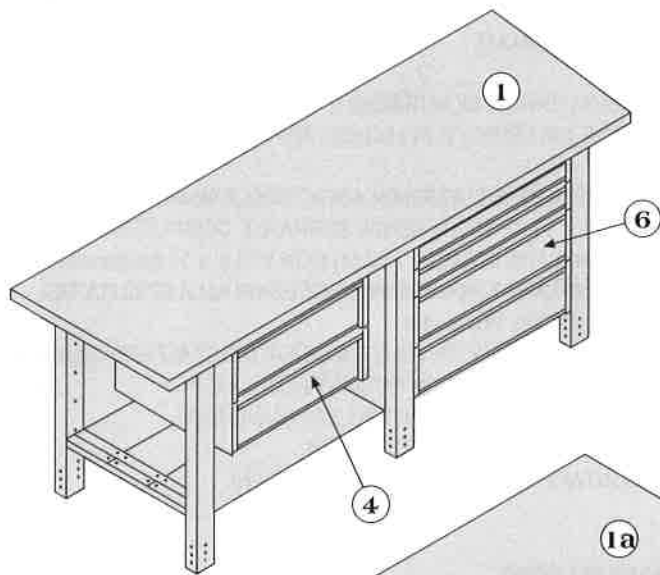

- ① PIANA IN FERRO
- ①a PIANA IN LEGNO
- ② TRAVERSINI
- ③ GAMBE
- ④ CASSETTO WORK 1
- ⑤ CASSETTIERA WORK 3
- ⑥ CASSETTIERA WORK 4
- ⑦ WORK 4 FREE
- ⑧ MANIGLIE
- ⑨ REGOLATORI ALTEZZE
- ⑩ RUOTE IN NYLON

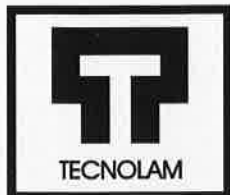

banco WERKMEISTER

ISTRUZIONI DI MONTAGGIO

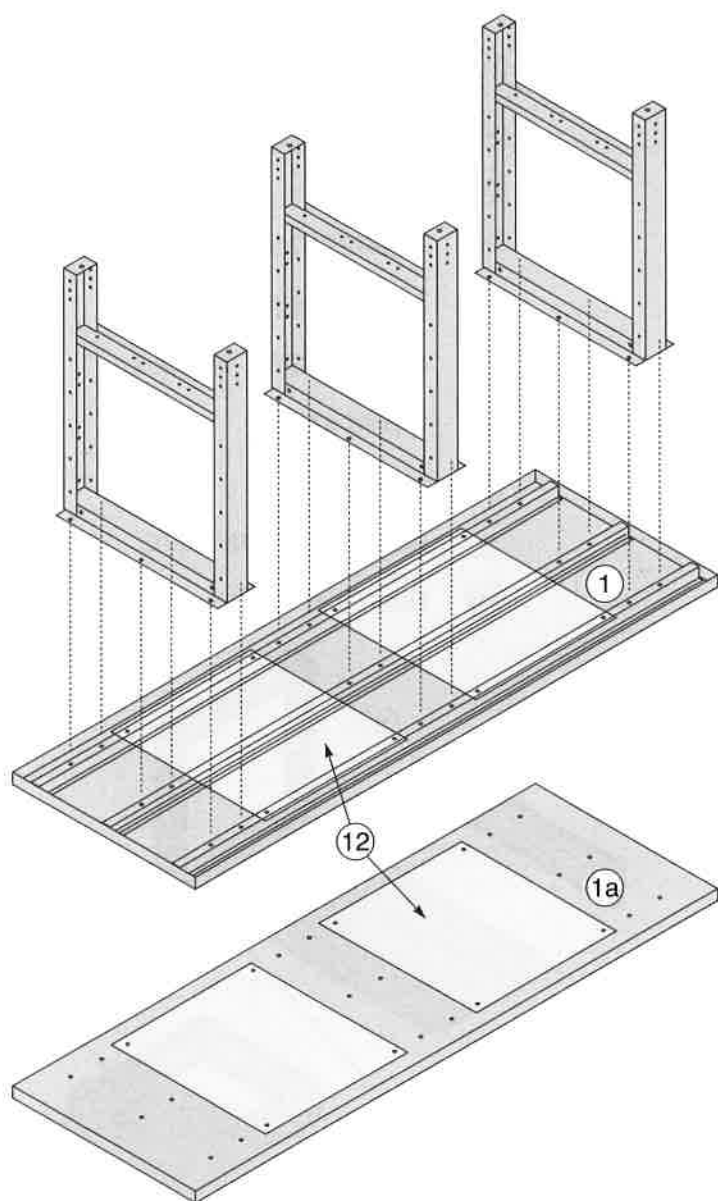

PIANA IN METALLO

PER FACILITARE IL MONTAGGIO E' CONSIGLIATO DI OPERARE CON LE PIANE (IN FERRO O IN LEGNO) APPOGGiate A TERRA.

- A) PROCEDERE ALL' ASSEMBLAGGIO DELLE GAMBE (3) CON VITI 8 x 16 (PART.11) SENZA SERRARLE COMPLETAMENTE.
- B) ASSEMBLARE IL CASSETTO (4) CON VITI 8 x 16 (opzionale).
- C) ASSEMBLARE I TRAVERSINI NECESSARI ALLA STABILITA' DEL TAVOLO CON VITI 6 x10.
- D) MONTARE LE RUOTE (9) E I REGOLATORI D' ALTEZZA (opzionale).
- E) PORTARE IL TAVOLO IN POSIZIONE DI LAVORO.
- F) COMPLETARE IL MONTAGGIO DEI TRAVERSINI.
- G) SERRARE TUTTE LE VITI E I DADI.
- H) MONTARE LE MANIGLIE (8) (OPZIONALE).

PIANA IN LEGNO

LA PIANA IN LEGNO E' PREFORATA PER L' INSERIMENTO DI VITI A LEGNO MORDENTI. (PART. 10)
WORK 3/4/4 VANNO INSERITI A BANCO MONTATO CON TUTTE LE VITE SERRATE.

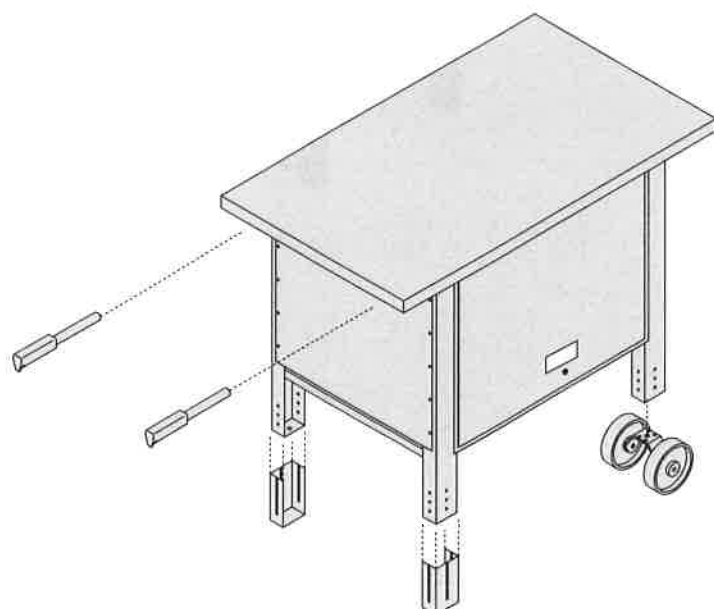
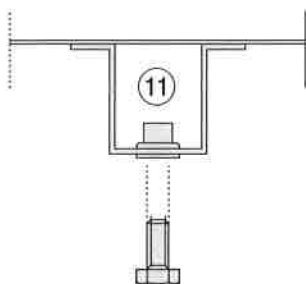
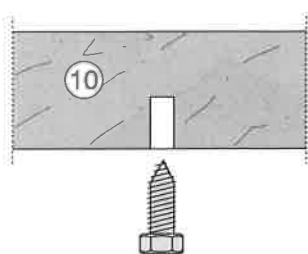

- ① PIANA IN FERRO
- ①a PIANA IN LEGNO
- ⑩ PARTICOLARE AGGANCIAMENTO PIANA IN LEGNO
- ⑪ PARTICOLARE AGGANCIAMENTO PIANA IN FERRO
- ⑫ FORI PER MONTAGGIO CASSETTO WORK 1

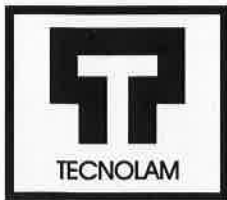

établi WERKMEISTER

INSTRUCTIONS DE MONTAGE

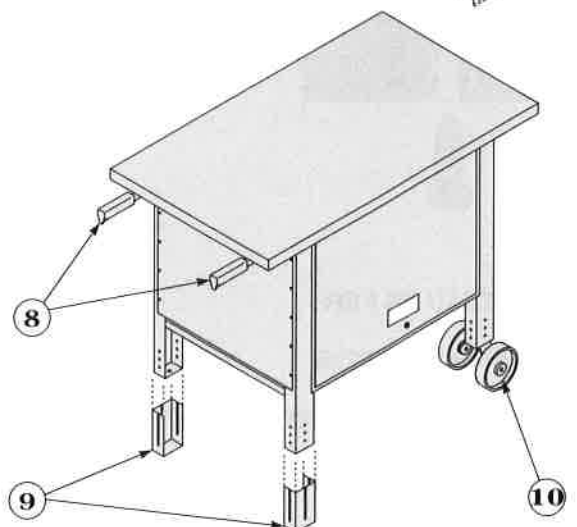
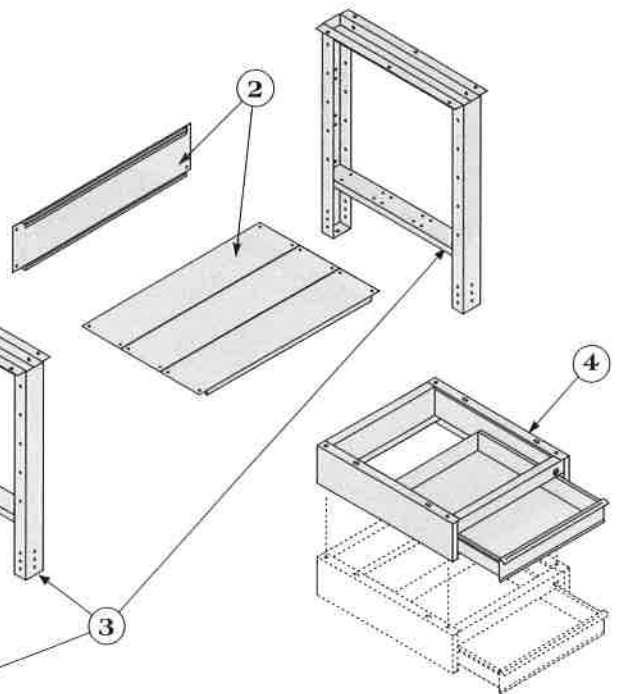
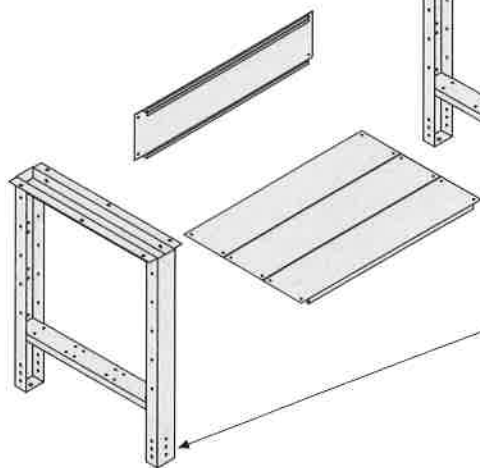
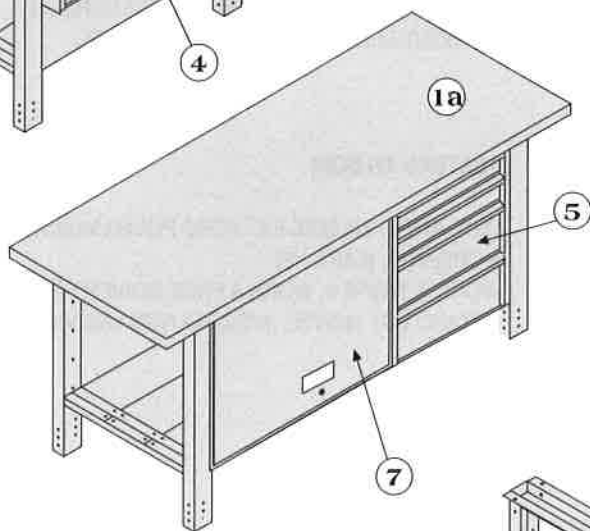
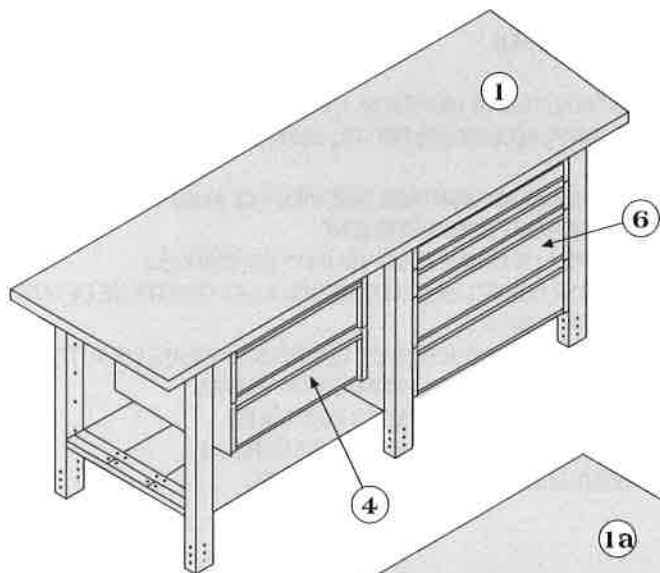

- ① PLATEAU EN FER
- ①a PLATEAU EN BOIS
- ② TÔLES
- ③ PIEDS
- ④ TIROIR WORK 1
- ⑤ BLOC À TIROIRS WORK 3
- ⑥ BLOC À TIROIRS WORK 4
- ⑦ WORK 4 FREE
- ⑧ POIGNÉES
- ⑨ REGULATEURS HAUTEUR
- ⑩ ROUES EN NYLON

PLATEAU EN FER

POUR FACILITER LE MONTAGE, ON CONSEILLE DE TRAVAILLER AVEC LES PLATEAUX (EN FER OU BOIS) POSÉS PAR TERRE.

- A) PROCEDEZ AU MONTAGE DES PIEDS (3) AVEC VIS 8X16, SANS LES SERRER COMPLÈTEMENT.
- B) MONTEZ LE TIROIR AVEC VIS 8X16 (OPTIONNEL)
- C) MONTEZ LES TÔLES NÉCESSAIRES À LA STABILITÉ DE L'ÉTABLI AVEC VIS 6X10.
- D) MONTEZ LES ROUES (9) ET LES RÉGULATEURS D'HAUTEUR
- E) PORTEZ L'ÉTABLI EN POSITION DE TRAVAIL
- F) COMPLETEZ LE MONTAGES DES TÔLES
- G) SERREZ TOUTES LES VIS ET LES ÉCROUS.
- H) MONTEZ LES POIGNÉES (OPTIONNEL)

PLATEAU EN BOIS

LE PLATEAU EN BOIS EST FORÉ POUR L'INSERTION DE VIS À BOIS MORDANTS (PART. 10)

WORK 3, WORK 4, WORK 4 FREE DOIVENT ÊTRE PLACÉS QUAND L'ÉTABLI EST MONTÉ, AVEC TOUTES LES VIS SERRÉES.

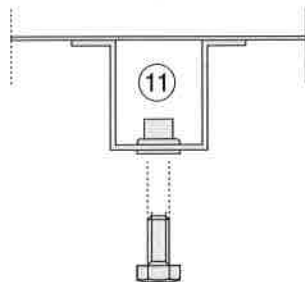
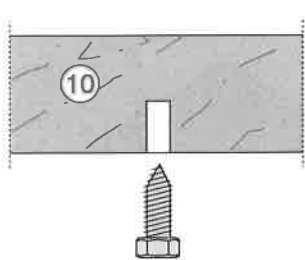
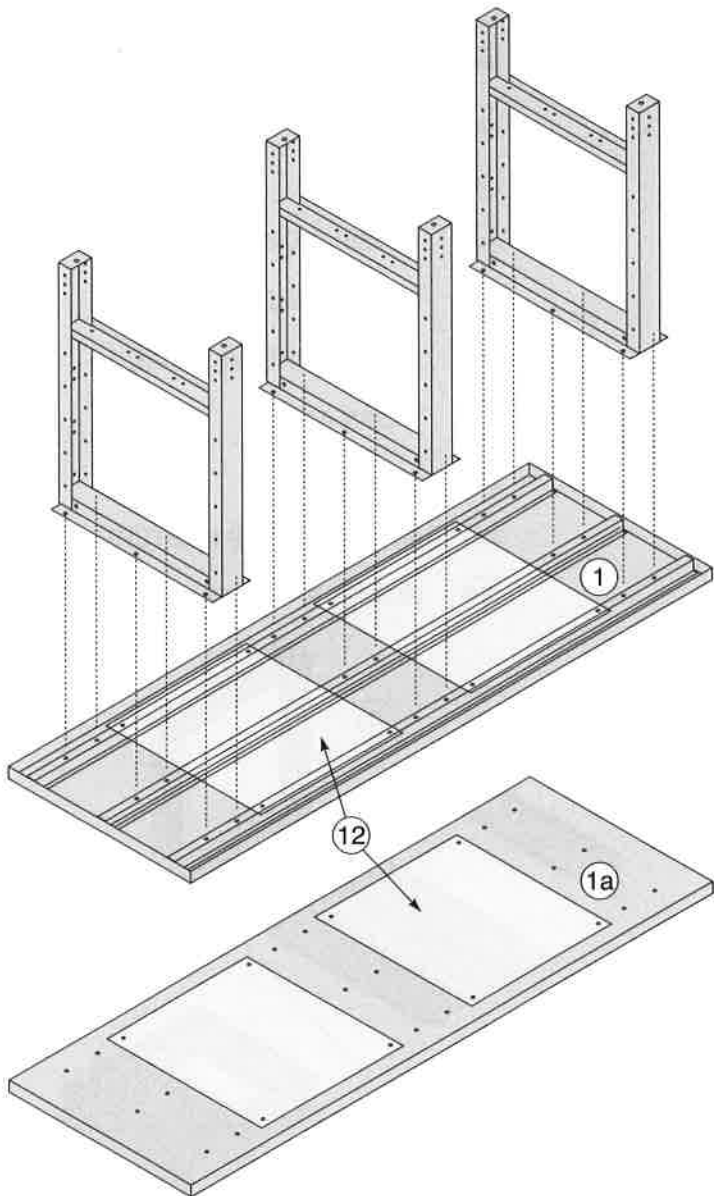

- ① PLATEAU EN FER
- ①a PLATEAU EN BOIS
- ⑩ ACCROCHAGE PARTICULAIRE PLATEAU EN BOIS
- ⑪ ACCROCHAGE PARTICULAIRE PLATEAU EN FER
- ⑫ TROUS POUR LE MONTAGE DU TIROIR WORK 1

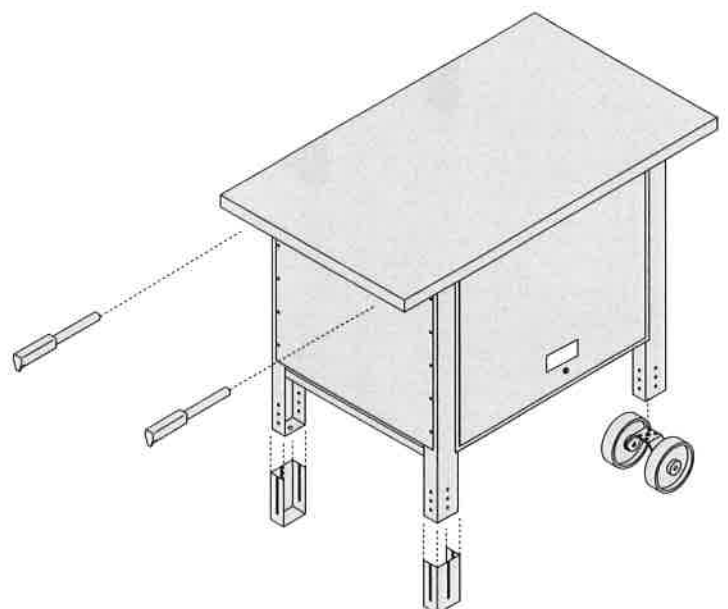



banco de trabajo WERKMEISTER

INSTRUCCIONES DE MONTAJE

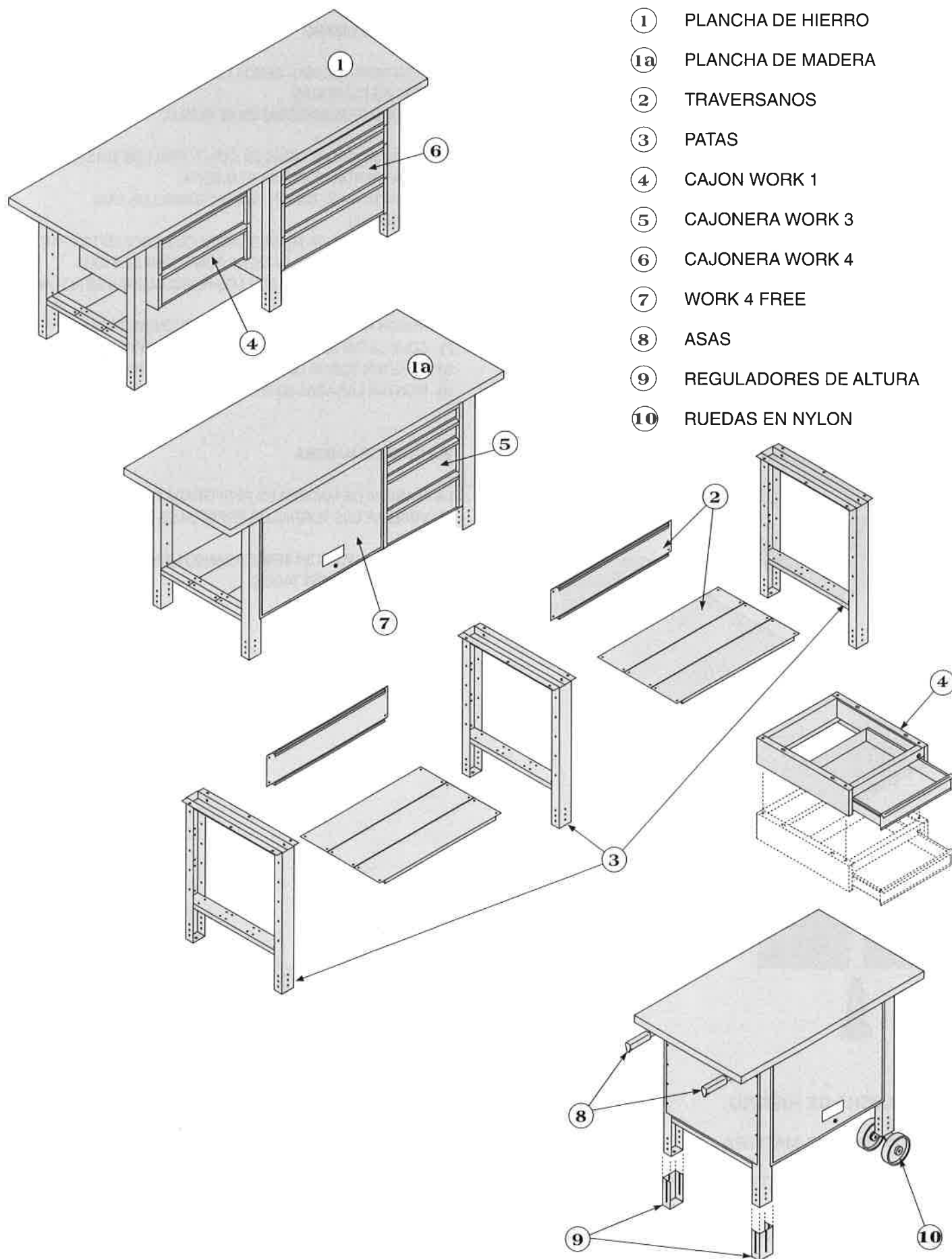

PLANCHA DE HIERRO

PARA UN MONTAJE MAS SENCILLO LES ACONSEJAMOS DE PONER LAS PLANCHAS (DE HIERRO O DE MADERA) EN EL SUELO.

- A) ENSAMBLAR LAS PATAS (3) CON TORNILLOS 8X16 (FIG.11) SIN APERTARLAS COMPLETAMENTE.
- B) ENSAMBLAR EL CAJON (4) CON TORNILLOS 8X16 (OPTIONAL).
- C) ENSAMBLAR LOS TRAVERSANOS QUE NECESITAN PARA LA ESTABILIDAD DE LA MESA CON TORNILLOS 6X10.
- D) MONTAR LAS RUEDAS (9) Y LOS REGULADORES DE ALTURA (OPTIONAL).
- E) PONER AHORA EL BANCO EN POSICION DE TRABAJO.
- F) COMPLETAR EL MONTAJE DE LOS TRAVERSANOS.
- G) APRETAR TODOS LOS TORNILLOS Y LAS TUERCAS.
- H) MONTAR LAS ASAS (OPTIONAL).

PLANCHA DE MADERA

LA PLANCHA DE MADERA ES PERFORADA PARA PODER ATORNILLAR LOS TORNILLOS ESPECIALES PARA MADERA (FIG.10)

ENSERIR LOS WORK 3/4/4FREE A BANCO MONTADO CON TODOS LOS TORNILLOS APRETADOS.

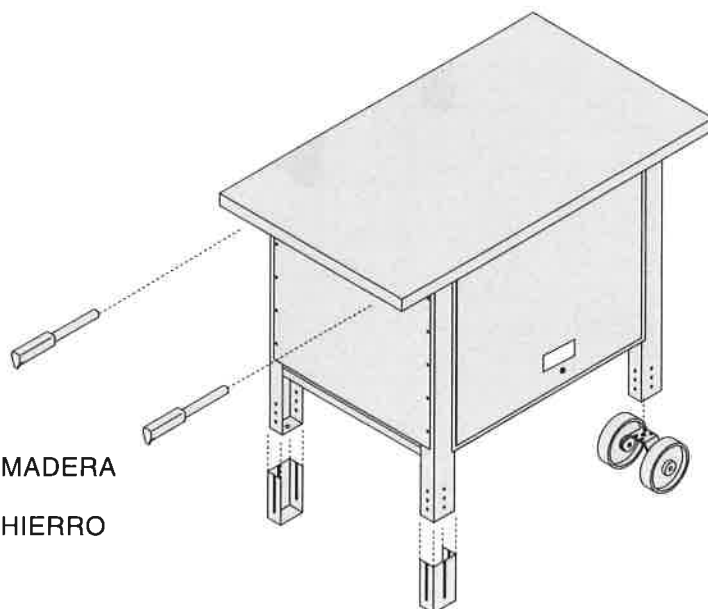
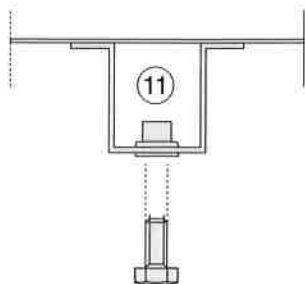
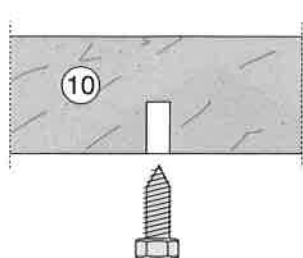
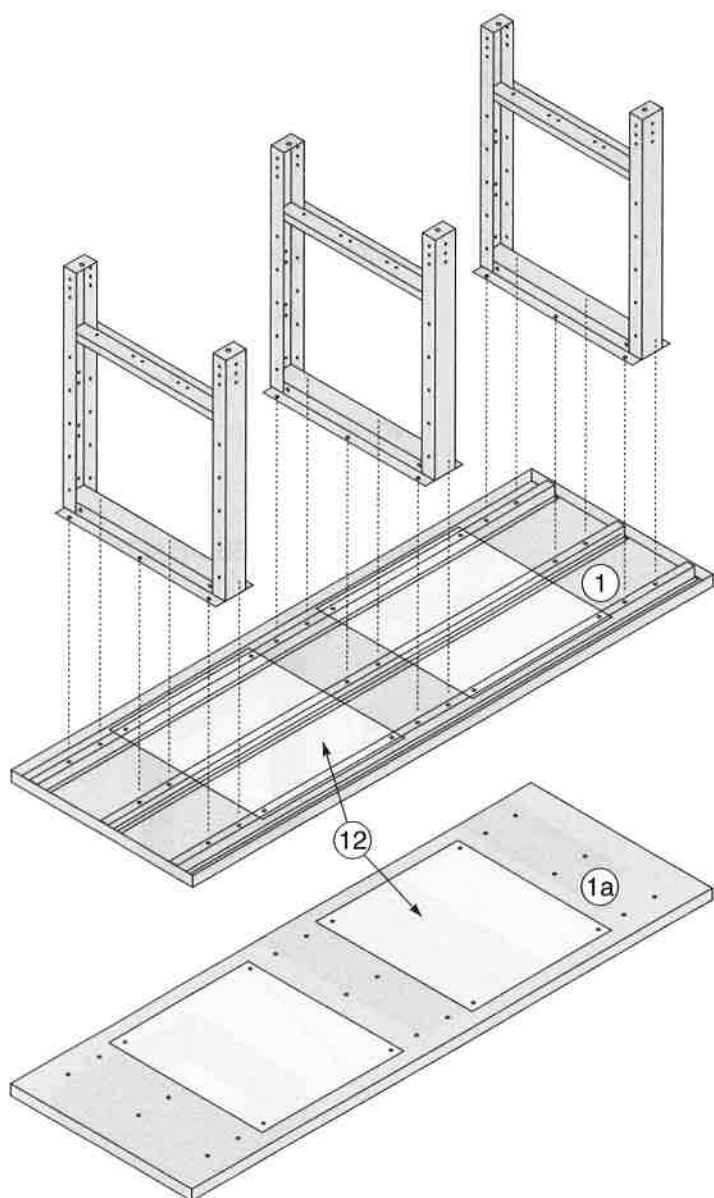

- ① PLANCHA DE HIERRO
- ①a PLANCHA DE MADERA
- ⑩ ENCLAJE CARACTERISTICO DE LA PLANCHA DE MADERA
- ⑪ ENCLAJE CARACTERISTICO DE LA PLANCHA DE HIERRO
- ⑫ AGUIJEROS PARA MONTAJE DEL CAJON WORK 1



Werkbank WERKMEISTER

MONTAGEANLEITUNG

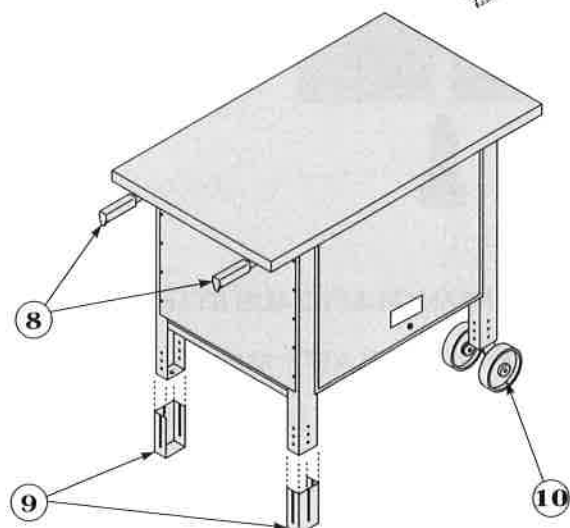
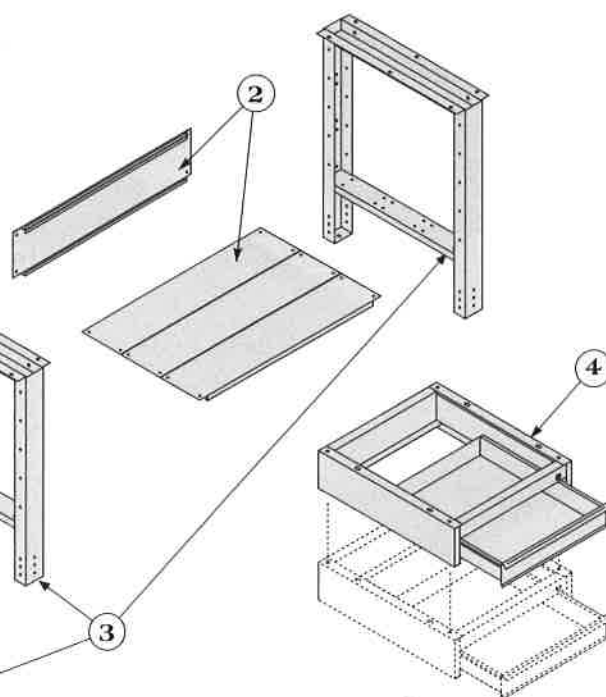
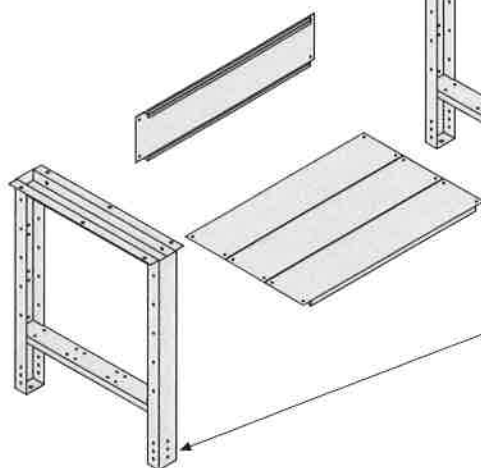
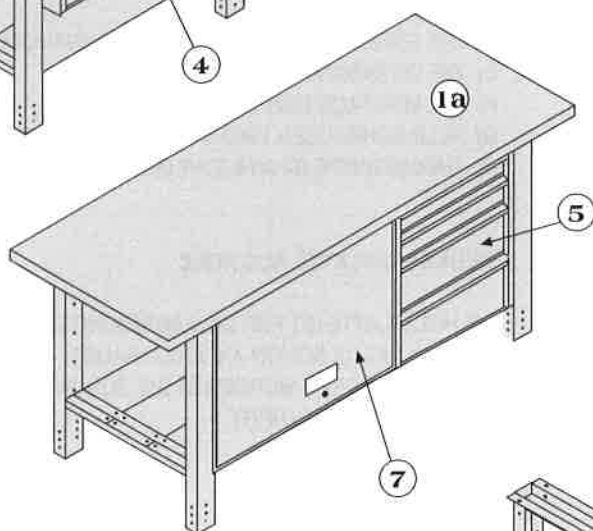
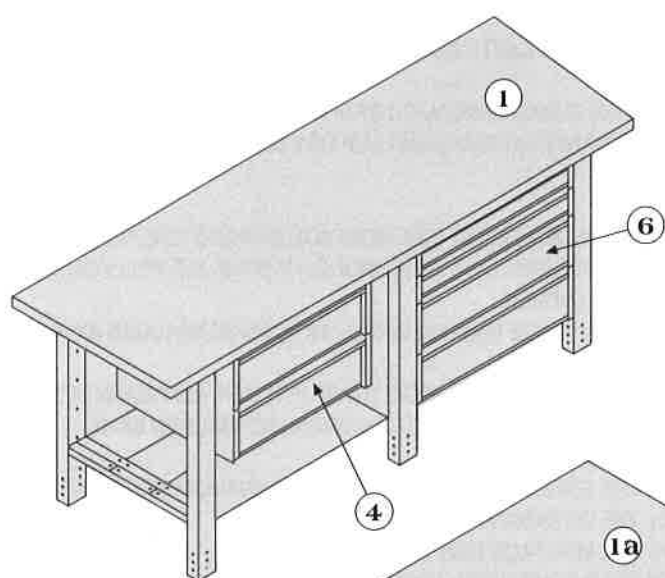

- ① WERKBANKPLATTE AUS STAHLBLECH
- ①a WERKBANKPLATTE AUS HOLZ
- ② TRAVERSEN
- ③ STÜTZBEINE
- ④ SCHUBLADE WORK 1
- ⑤ SCHUBLADENSCHRANK WORK 3
- ⑥ SCHUBLADENSCHRANK WORK 4
- ⑦ WOLF 4 FREE
- ⑧ HANDGRIFFE
- ⑨ HÖHENREGLER
- ⑩ GUMMIRÄDER

WERKBANKPLATTE AUS STAHLBLECH

UM DEN ZUSAMMENBAU ZU ERLEICHTERN, IST ES RATSAM DIE WERKBANKPLATTEN DABEI AUF DEN BODEN ZU LEGEN.

- A) BEGINNEN SIE MIT DER MONTAGE DER STÜTZBEINE (3) MIT DEN SCHRAUBEN 8X16 (ZEICHNUNG 11) OHNE SIE VOLLKOMMEN ANZUZIEHEN.
- B) SCHUBLADE (4)(WAHLWEISE) MIT DEN SCHRAUBEN 8X16 MONTIEREN.
- C) TRAVERSEN, DIE FÜR DIE STABILITÄT DER WERKBANK BENÖTIGT WERDEN, MIT DEN STÜTZBEINEN (SCHRAUBEN 6X10) MONTIEREN.
- D) DIE RÄDER (9) UND HÖHENREGLER (WAHLWEISE) MONTIEREN.
- E) DIE WERKBANK AUFSTELLEN.
- F) DIE MONTAGE DER TRAVERSEN BEENDEN.
- G) ALLE SCHRAUBEN UND MUTTERN ANZIEHEN.
- H) HANHDGRIFFE (8) (WAHLWEISE) MONTIEREN.

WERKBANKPLATTE AUS HOLZ

DIE HOLZPLATTE IST FÜR DIE EINFÜGUNG DER MADENSCHRAUBEN (ZEICHNUNG 10) SCHON ANGESCHRAUBT. WORK 3/ 4 / 4 FREE WERDEN IN DIE SCHON FESTGESCHRAUBTE WERKBANK EINMONTIERT.

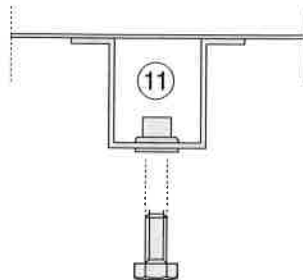
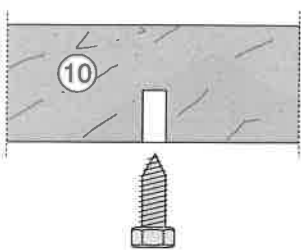
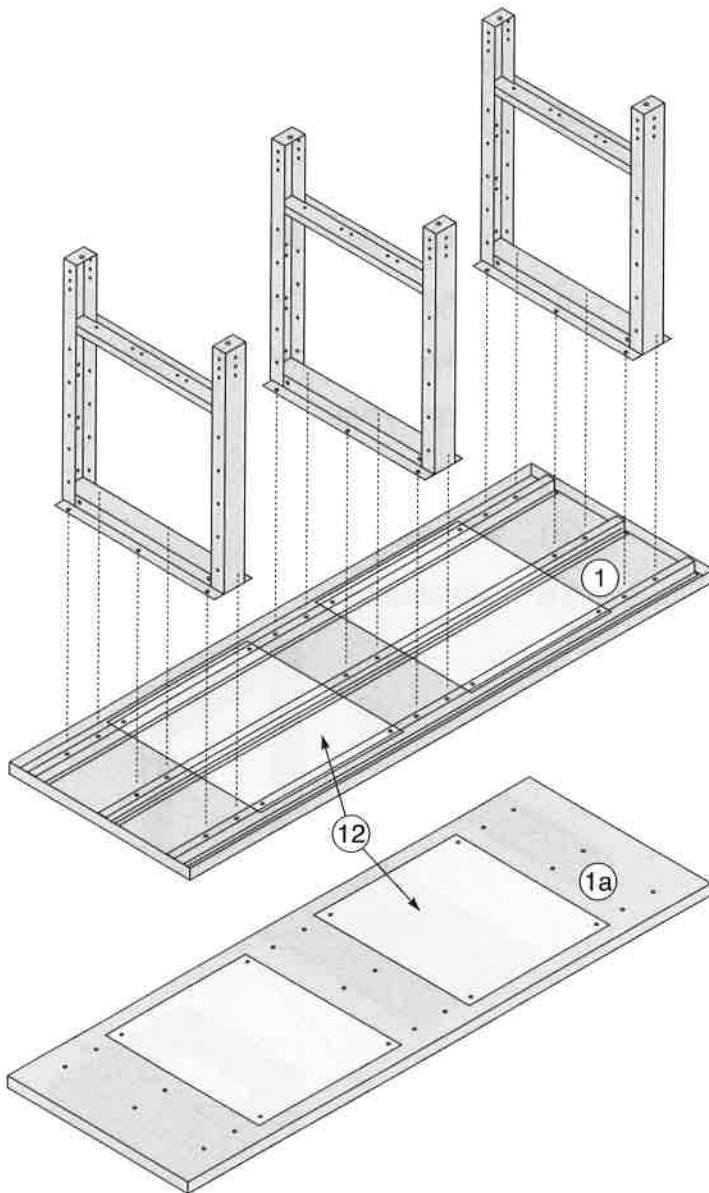

- ① WERKBANKPLATTE AUS STAHLBLECH.
- ①a WERKBANKPLATTE AUS HOLZ.
- ⑩ ZEICHNUNG FÜR DIE ANBRINGUNG DER HOLZPLATTE.
- ⑪ ZEICHNUNG FÜR DIE ANBRINGUNG DER STAHLBLECHPLATTE.
- ⑫ BOHRUNGEN FÜR DIE MONTAGE DER SCHUBLADE.

